

Memorandum of common provisions
Restrictive covenants in a plan
Section 91A Transfer of Land Act 1958

Privacy Collection Statement

The information in this form is collected under statutory authority and is used for the purpose of maintaining publicly searchable registers and indexes.

Lodged by	
Name:	
Phone:	
Address:	
Reference:	
Customer code:	

This memorandum contains provisions which are intended for inclusion in plans under the Subdivision Act 1988 to be subsequently lodged for registration.

Operative words including words to bind the burdened land and words of annexation must not be included.

Burdened Land: As set out in the Plan of Subdivision

Benefited Land: As set out in the Plan of Subdivision

Covenants:

A. Preliminary

- A. This MCP (Version 5) provides the information necessary to interpret the approved building envelopes.
- B. This MCP includes:
 - a) Any varied design parameters from the Building Regulations.
 - b) Matters not covered by the Building Regulations.
- C. Any matter not addressed in this MCP will still need to be addressed as required by the Building Regulations.
- D. This MCP is retained by the Registrar of Titles pursuant to-section 91(A) of the Transfer of Land Act.

B. Provisions

- A. Any building requiring a building permit to be constructed on a lot to which this MCP applies must be sited within the approved building envelope.
- B. This MCP will specify any encroachments allowed outside the approved building envelope.

1. House Design

- 1.1. Written approval of the Architectural Review Panel (ARP) is required prior to the issue of a building permit or commencement of construction of a new home, garage, shed, fence, retaining wall or other structure.

35402012

V3

- 1. The provisions are to be numbered consecutively from number 1.
- 2. Further pages may be added but each page should be consecutively numbered.
- 3. To be used for the inclusion of provisions in plans.

91ATLA

Page 1 of 18

THE BACK OF THIS FORM MUST NOT BE USED

Land Use Victoria contact details: see www.delwp.vic.gov.au/property>Contact us

Memorandum of common provisions

Section 91A Transfer of Land Act 1958

- 1.2. Home elevations facing the street frontage(s) must be articulated, incorporating various planes or setbacks to façade elements. The use of elements such as verandas, balconies, and pergolas may contribute to meeting this requirement.
- 1.3. Use of a combination of wall materials and colours is required to achieve visual interest and articulation. A minimum of two different materials (excluding windows and garage doors) must be used, with the secondary material covering a minimum of 20% of the overall area.
- 1.4. Large expanses and uninterrupted use of conventional brickwork and blockwork visible from the street frontages(s) are not permitted.
- 1.5. A minimum of 60% of the home elevations visible from the street (excluding windows and garage doors) must feature blockwork, stone, brick, or cement render /applied textured finish. No more than 40% of the home elevations visible from the street (excluding windows and garage doors) may be weatherboard.
- 1.6. Homes on corner lots must address both street frontages, utilising articulated façade elements and windows to present an appealing and harmonious aspect to both elevations visible from the street. Windows facing the secondary street frontage and visible from the street must have identical head and sill heights to windows on the front of the home. Materials on the front façade of the home must be incorporated into the façade facing the secondary street frontage visible from the street.
- 1.7. Homes must not feature a substantially identical façade to any home within five lots.
- 1.8. Front entry doors must feature clear glazed sidelights or glazed panels, be clearly visible from the street frontage and be incorporated into a porch, portico or verandah with an area of not less than 4m² measured to the roofline.
- 1.9. Pitched roofs (including garage roofs) visible from the street frontage(s) must feature a minimum of pitch of 22.5°, unless approved by the ARP on design merit. Flat roofs with a pitch below 5° (including garage roofs) visible from the street frontage(s) must be enclosed behind a parapet to the street frontage(s).
- 1.10. Pitched roofs (including garage roofs) visible from the street frontage(s) must feature a minimum eave width of 450mm (unless the wall is on a lot boundary or is a parapet wall). Eaves to front façades must return around the sides of the home a minimum of 4m. Double-storey homes must have eaves to all sides on the upper level.
- 1.11. Roofs visible from street frontage(s) must be constructed of corrugated Colorbond (e.g. custom orb) or terracotta, slate or concrete tiles and must be non-reflective.
- 1.12. To provide variation in built form, some home sites are designated in the plan of subdivision as double-storey only. Homes built on these lots must be double-storey.
- 1.13. The upper level of two-storey homes must feature a different material, setbacks or articulation (recession and projection of planes) from the ground floor wall lines for elevations facing the street frontage(s).
- 1.14. Overlooking controls apply to any habitable upper level room window, balcony, terrace, deck or patio of a home within the specified overlooking control area (as identified in the relevant setback profile codes shown on the building envelope plan), that has a direct view into an adjoining lot.
- 1.15. Lightweight cladding above windows and openings visible from the street frontage(s) that is not finished flush with the surrounding walls and matches the finish and colour of the surrounding façade is not permitted.
- 1.16. Roller shutters are not permitted on doors and windows visible from the street frontage(s).

Memorandum of common provisions

Section 91A Transfer of Land Act 1958

- 1.17. Where lightweight cladding is used on the upper level of the rear elevation, its colour must match the remainder of the upper-level elevations.
 - 1.18. Homes on lots with significant slope must be designed to minimise cut and fill. Split-level designs which respond to the natural contours of the land are encouraged. Excessively large site cuts are not permitted.
 - 1.19. Only muted or non-reflective external colours may be used.
 - 1.20. External surfaces of homes must not be constructed of the following materials:
 - 1.20.1. second-hand building materials without the approval of the ARP on architectural merit,
 - 1.20.2. unfinished fibre-cement sheeting or blue board sheeting,
 - 1.20.3. weatherboards with an exposed height of greater than 180mm,
 - 1.20.4. fascia boards, trim and exposed metalwork that are not colour co-ordinated with the home, or
 - 1.20.5. reflective glazing or excessively tinted glass.
 - 1.21. Relocated or transportable homes are not permitted (unless approved by the ARP on design merit).
 - 1.22. Homes with exposed stumps or support posts (excluding veranda or pergola posts) are not permitted.
 - 1.23. External plumbing (excluding downpipes or guttering) must be out of public view from the street frontage(s).
 - 1.24. Meter boxes must not be positioned to face street frontage(s) and must be contained within a wall.
 - 1.25. External antennae and aerials, satellite dishes, rainwater tanks, clothes lines, evaporative coolers and other air conditioning units must be positioned to minimise their visibility from the street frontage(s).
 - 1.26. Storage space for waste, recycling and optional green waste bins must be located within an area not visible from the street.
- 2. Energy Efficiency**
- 2.1. Homes must be designed to maximise winter sun penetration through the appropriate placement and sizing of windows and minimise summer sun through external shading. At least one living / family / lounge area must have a north facing window or windows with a total area of not less than 5m² with an external shading device such as an eave, pergolas or external blind (unless the home is on a lot with a south-facing rear yard).
- 3. Water Efficiency**
- 3.1. Toilets and garden taps must be connected to recycled water.
- 4. Lot Layout**
- 4.1. Only one home may be built on each lot.
 - 4.2. Lots may not be further subdivided.
 - 4.3. Homes must be set back from a street frontage boundary in accordance with the applicable setback identified in the building envelope plans subject to the allowable encroachments specified in the building regulations.

Memorandum of common provisions

Section 91A Transfer of Land Act 1958

- 4.4. Homes must be set back from the side and rear boundaries in accordance with the applicable setback profiles as identified in the building envelope plans subject to the allowable encroachments specified in the building regulations.
- 4.5. If the building envelope plans shows the profile identifier codes A and B on opposite side boundaries, the codes can be interchanged.
- 4.6. Construction within 200mm of a boundary is only permitted where the setback profiles identified in the building envelope plans indicate a building area on the boundary.

5. Garages

- 5.1. All homes must feature a lock up garage with a panel lift door integrated into the design of the home. For single storey homes, the width of the garage opening must not exceed 40% of the lot width. For double storey homes, the area of the garage opening must not exceed 25% of the total area of the front façade.
- 5.2. Garages must be positioned a minimum of 840mm behind the adjoining front wall of the home.
- 5.3. Garages must be setback at least 5.5m from the front boundary
- 5.4. Homes on corner lots must have the garage door located on or close to a boundary with an adjoining lot.
- 5.5. Garages with a side wall that faces a street frontage must feature windows in the side wall to match the home.
- 5.6. All homes must have wiring provision within the garage suitable for electric vehicle charging. A single 32A, 240 Volt General Purpose Outlet on a dedicated circuit to a 40A single phase Type A residential current device or circuit breaker (or other electrical provision in accordance with a manufacturer's specification for electric vehicle charging) must be located in a suitable position on an internal garage wall. The location of a meter box on an outside wall of the garage and not facing a street frontage, allowing cost-effective addition of electrical wiring to a point inside the garage at a later date, will be deemed to satisfy this requirement.

6. Driveway

- 6.1. Driveways must be constructed of pavers, coloured concrete in a neutral tone, or exposed aggregate concrete finish. Plain concrete and gravel are not permitted.
- 6.2. The driveway must be completed prior to the home being occupied.
- 6.3. The driveway must be constructed to match the location and width of the existing driveway crossover.
- 6.4. A minimum allowance of 300mm for garden planting is required between a driveway and a side boundary. This does not apply when a crossover is constructed as part of a double-crossover with an adjoining lot. Landscaping strips are not permitted between double crossovers.
- 6.5. Relocation of a driveway crossover may be permitted with the written approval of Cardinia Shire Council. Relocated crossovers must be constructed at the purchaser's expense to the specification of Cardinia Shire Council and be of the same finish as that originally constructed. Upon construction of a new crossover, the original crossover must be removed and the nature strip reinstated.
- 6.6. Construction of an additional driveway crossover to a corner lot may be permitted with the written approval of Cardinia Shire Council. Additional crossovers must be constructed at the purchaser's expense to the specification of Cardinia Shire Council and be of the same finish as that originally constructed.

Memorandum of common provisions

Section 91A Transfer of Land Act 1958

7. Landscaping

- 7.1. Plant species which appear on the Cardinia weed identification guide must not be planted or allowed to grow. The Cardinia weed identification guide can be accessed from the Arbor web site at arborofficer.com.au/sustainability.
- 7.2. Landscaping to the front garden is to include:
 - 7.2.1. One semi-advanced tree no less than one metre in height when planted,
 - 7.2.2. minimum of 15m² of mulched garden bed, and
 - 7.2.3. any grassed areas must be either turf or seeded lawn (synthetic grass is not permitted)
- 7.3. Landscaping of the front garden must be completed within 90 days of a certificate of occupancy being issued.
- 7.4. Retaining walls visible from the street frontage(s) must be constructed in materials to complement the landscape, such as rock, stone or timber sleepers. Where the change in level is greater than 1m, multiple stepped retaining walls with appropriate landscaping are required.

8. Outbuildings

- 8.1. Outbuildings, including garden sheds, must be visually harmonious with the home. Plans, elevations and schedule of external materials and colours must be provided to the ARP for approval for any outbuildings larger than 3m wide x 3.5m deep x 2.5m high.

9. Letter Boxes

- 9.1. Letter boxes must be constructed in materials to complement the home, be located on the front property boundary and clearly identify the house number. Single post supported letter boxes are not permitted.

10. Fences

- 10.1. All fences shall:
 - 10.1.1. not exceed 1.85m in height above the natural ground level;
 - 10.1.2. not be constructed any closer to the street frontage than 2m behind the front wall of the home closest to the street boundary; and
 - 10.1.3. be constructed from timber palings and must have timber capping with timber posts exposed to both sides of the fence (except for the section of fence facing the street frontage on either side of the home, which may be constructed of horizontal, stained timber slats no greater than 50mm wide or other materials approved in writing by the ARP on architectural merit) and,
- 10.2. Corner allotments can construct timber fencing (with timber capping with timber posts exposed to both sides of the fence) on the boundary along the longest street frontage provided that:
 - 10.2.1. the fence is no longer than 50% of the street frontage;
 - 10.2.2. the fence does not directly face a landscaped reserve; and
 - 10.2.3. a minimum of two recessed bays 600mm setback from the boundary and a minimum of 3m in length are included, with planting provided in these bays.
- 10.3. Fences must not be painted or stained.

Memorandum of common provisions

Section 91A Transfer of Land Act 1958

- 10.4. Fences constructed on top of a retaining wall visible from the street frontage(s) must be setback a minimum of 450mm from the exposed face of the retaining wall and landscaping provided between the fence and retaining wall.
- 10.5. The fencing restrictions do not apply if the home on the lot is being used as a display home. However, the fencing must comply with the restrictions after the home on the lot ceases to be used as a display home.

11. Design Approval

- 11.1. Written approval of the Architectural Review Panel (ARP) is required prior to the issue of a building permit or commencement of construction.
- 11.2. The design of any building or structure to be constructed on a lot, must, up until 31 December 2028, receive approval from the ARP of the plans and specifications (detailed in Clause 11.3) (email: approvals@arborofficer.com.au) prior to the issue of a building permit or commencement of construction.
- 11.3. The following documents are required to be submitted to the ARP for approval:
 - 11.3.1. Site Plan - including setbacks from all boundaries and locations of the rainwater tank, clothesline, storage space for waste and recycling bins, driveway, and any sheds or outbuildings;
 - 11.3.2. Dimensioned floor plan;
 - 11.3.3. Elevations - from four sides showing building heights, roof pitches, electrical meter box, fibre optic connections, gas meters, external air-conditioners, and aerials;
 - 11.3.4. Schedule of external materials and colours;
 - 11.3.5. Details of any earthworks and retaining walls including materials used;
 - 11.3.6. Simple sketch plan showing landscaping between the street frontage(s) and the home including location of any paths, mulched beds, trees, driveway (including materials used) and an image or drawing of the proposed letterbox;
 - 11.3.7. Fencing details - including locations, heights, and materials;
 - 11.3.8. Plans, elevations and a schedule of external materials and colours are also required for any outbuildings larger than 3m wide x 3.5m deep x 2.5m high;
- 11.4. All plans must be legible when printed to A3, drawn to a conventional scale and clearly show the direction of north. The Architectural Review Panel reserves the right to request additional information.

12. Permission to construct contrary to these MCPs and any Building Envelope

- 12.1. The Architectural Review Panel retains final discretion on all matters and may allow deviations to the design guidelines and the MCP in exceptional circumstances.
- 12.2. The requirements of these MCPs may be varied with the consent of the Responsible Authority and when:
 - 12.2.1. where consent of the Responsible Authority is required by the Scheme;
 - 12.2.2. a planning permit is issued affecting the lot;
 - 12.2.3. required by operation of the law.

Memorandum of common provisions

Section 91A Transfer of Land Act 1958

13. Notes on this MCP

13.1. Conflicting Annotation

- 13.1.1. In the case of a conflicting annotation between the building envelope plan and this MCP text, the MCP text takes precedence.
- 13.1.2. In the case of conflict between the Arbor Officer Design Guidelines and this MCP text, the MCP text takes precedence.

13.2. Natural Ground Level

- 13.2.1. Ground level after engineering works associated with the subdivision is to be regarded as natural ground level.

13.3. Easements

- 13.3.1. Buildings must not cover registered easements unless approved by the relevant authority.

14. General Definitions

- 14.1. **Approved building envelope** means the building envelope for a particular lot contained in the building envelope plan which is attached to this MCP and has the same meaning as in regulation 71 of the Regulations.
- 14.2. **Arbor Officer Design Guidelines** means the design guidelines prepared by Arbor and Southern Sustainable Development (Officer), as amended from time to time.
- 14.3. **Building** has the same meaning as in the Building Act
- 14.4. **Building Act** means the act of the Victorian Parliament known as the Building Act 1993, and any re-enactment or replacement of that act.
- 14.5. **Building envelope** means an area within each lot where development of a dwelling, shed and garage is allowed subject to the provisions of this MCP.
- 14.6. **Building envelope plan** means the plan which is attached to this MCP showing dwelling setbacks and other related matters.
- 14.7. **Building Permit** means a permit in terms of the Building Act.
- 14.8. **Corner lot** means a lot sited at the intersection of two streets (excluding laneways) where those streets form boundaries of the lot
- 14.9. **Dwelling** has the same meaning as in the Scheme;
- 14.10. **Front boundary** means;
 - 14.10.1. In the case of a lot where only one boundary abuts a road, that boundary which abuts the road; or
 - 14.10.2. In the case of a lot where more than one boundary abuts a road, the shortest of the boundaries which abuts a road and where there is a splayed corner on a lot, that part of the boundary which is created by the splay (the corner section) shall be disregarded.
- 14.11. **Front Building Line** means the front façade wall excluding any façade treatment or pier.
- 14.12. **Height** has the same meaning as in the Regulations.

Memorandum of common provisions

Section 91A Transfer of Land Act 1958

- 14.13. **Home** has the same meaning as building as in the Building Act.
- 14.14. **Lot** has the same meaning as in the Subdivision Act 1988, and any re-enactment or replacement of that act.
- 14.15. **MCP** means this memorandum of common provisions
- 14.16. **On the boundary** means a setback of up to 200 millimetres from the property title boundary.
- 14.17. **Plan of subdivision** means the plan of subdivision to which this MCP is incorporated by way of a restrictions on that plan of subdivision.
- 14.18. **Regulations** means the Building Regulations 2018 or any subsequent regulations made pursuant to the Building Act.
- 14.19. **Reserve** has the same meaning as in the Subdivision Act 1988, and any re-enactment or replacement of that act.
- 14.20. **Return fence** means the fence that is situated between the dwelling and the side boundary fence, or on a corner lot, between the dwelling and a side boundary fence along a secondary street frontage.
- 14.21. **Road** means any kind of road, street, lane or other vehicular access way whatsoever and has the same meaning as in the Road Management Act 2004 and any re-enactment or replacement of that act.
- 14.22. **Scheme** means the planning scheme of the local authority responsible for the land contained within the plan of subdivision.
- 14.23. **Secluded Private Open Space** has the same meaning as in the building regulations.
- 14.24. **Secondary Street Frontage** is any boundary that abuts a road or reserve, other than the Front Boundary
- 14.25. **Setback** has the same meaning as in the Regulations.
- 14.26. **Side boundary** means a boundary of a lot that runs between and connects the front boundary of the lot to the rear boundary of the lot.
- 14.27. **Street**, for the purposes of determining street setbacks, means any road other than a footway or carriageway easement.

Expiry:

As set out in the Plan of Subdivision (if applicable); and

A building envelope will cease to apply to any building on the lot affected by the building envelope after the issue of a certificate of occupancy for the whole of a dwelling on the land.

Memorandum of common provisions
Section 91A Transfer of Land Act 1958

15. Diagrams and Plans

15.1 Diagram illustrating the interpretation of the building envelope and the annotation with respect to all edge lots in this stage development

15.1.1 Typical Building Envelope

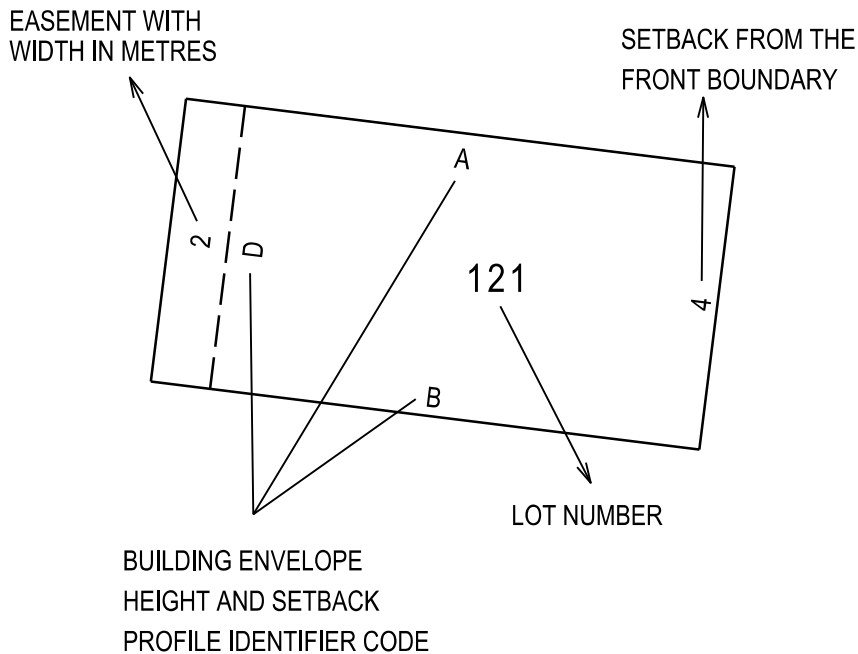

15.1.2 Custom Building Envelope

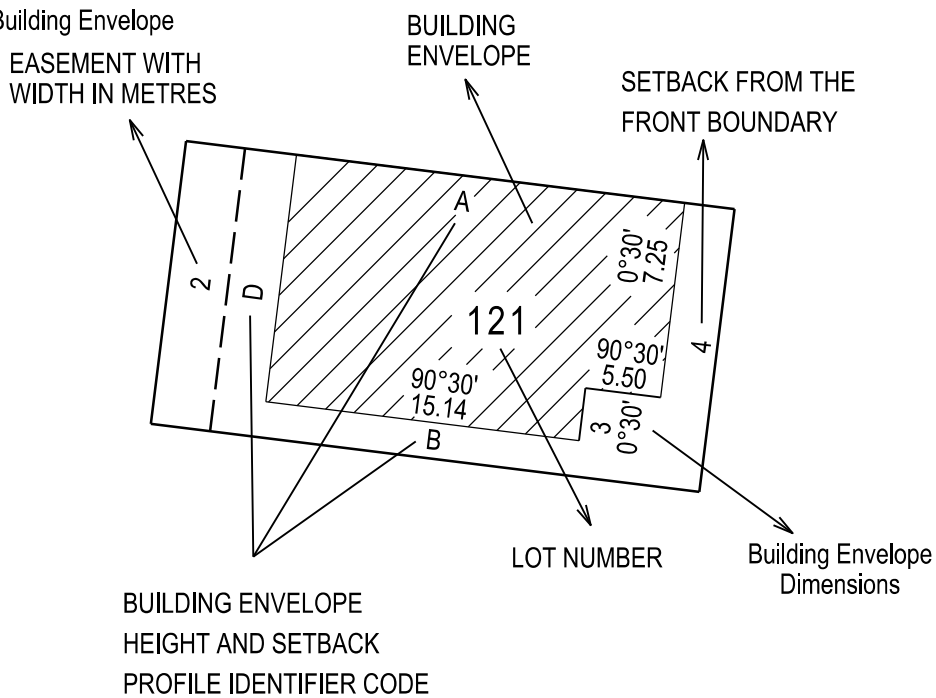

For lots shown with a building envelope height and setback profile identifier code, as well as a hatched building envelope, both the profile identifier code and the hatched building envelope must be adhered.

Memorandum of common provisions

Section 91A Transfer of Land Act 1958

15.2 Building height & setback profiles referenced in the building envelope plan

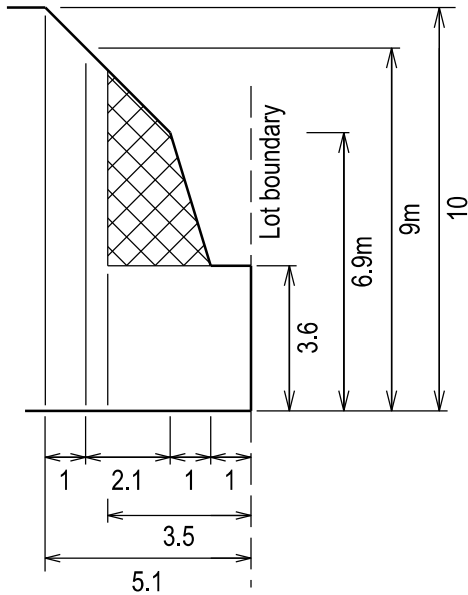

Side boundary shared with the side or rear boundary of a residential lot in the same development stage

PROFILE (A)

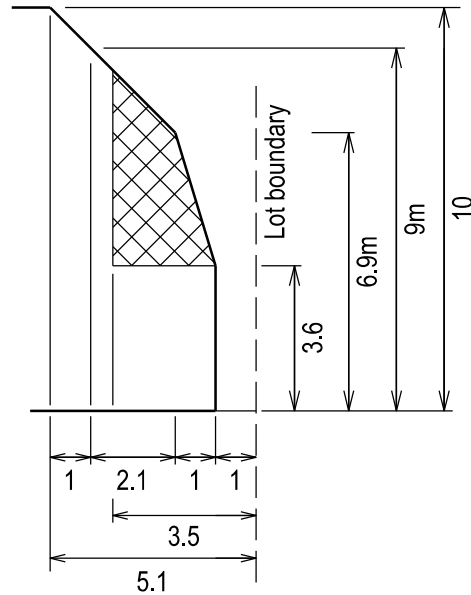

Side boundary shared with the side or rear boundary of a residential lot in the same development stage

PROFILE (B)

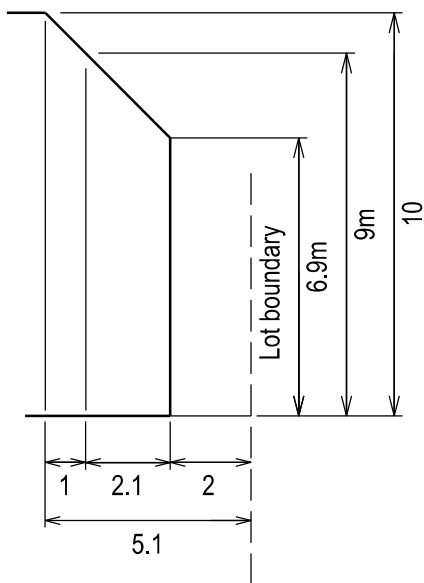

Side boundary abutting a street or public open space

PROFILE (C)

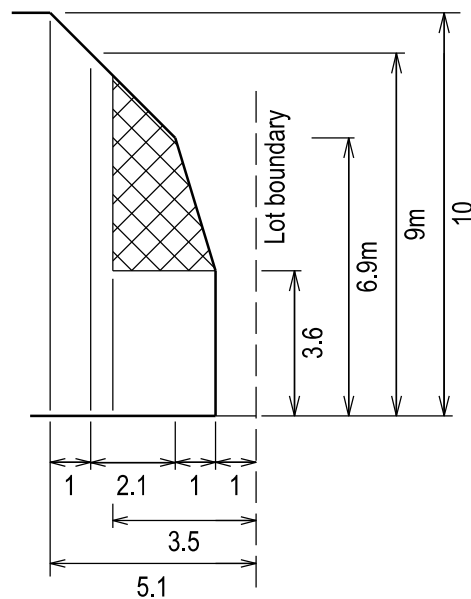

Rear boundary adjoining the rear or side boundary of a residential lot

PROFILE (D)

EASEMENT REQUIREMENT

WHERE A PROFILE WHEN APPLIED COVERS AN EASEMENT, THE PORTION OF THE PROFILE ABOVE THE EASEMENT CANNOT BE CONSIDERED FOR APPROVAL/BUILT UPON. THIS MAY VARY ONLY IN THE CIRCUMSTANCES WHERE BUILDING ON THE EASEMENT RECEIVES PRIOR WRITTEN CONSENT OF THE RELEVANT AUTHORITY.



OVERLOOKING CONTROL AREA (refer 'overlooking' in MCP)

ALL DIMENSIONS ARE IN METRES UNLESS NOTED OTHERWISE

Memorandum of common provisions
Section 91A Transfer of Land Act 1958

15.3 Diagram illustrating the interpretation of the building envelope and the annotation with respect to all edge lots in this stage development

SEE SHEET 12

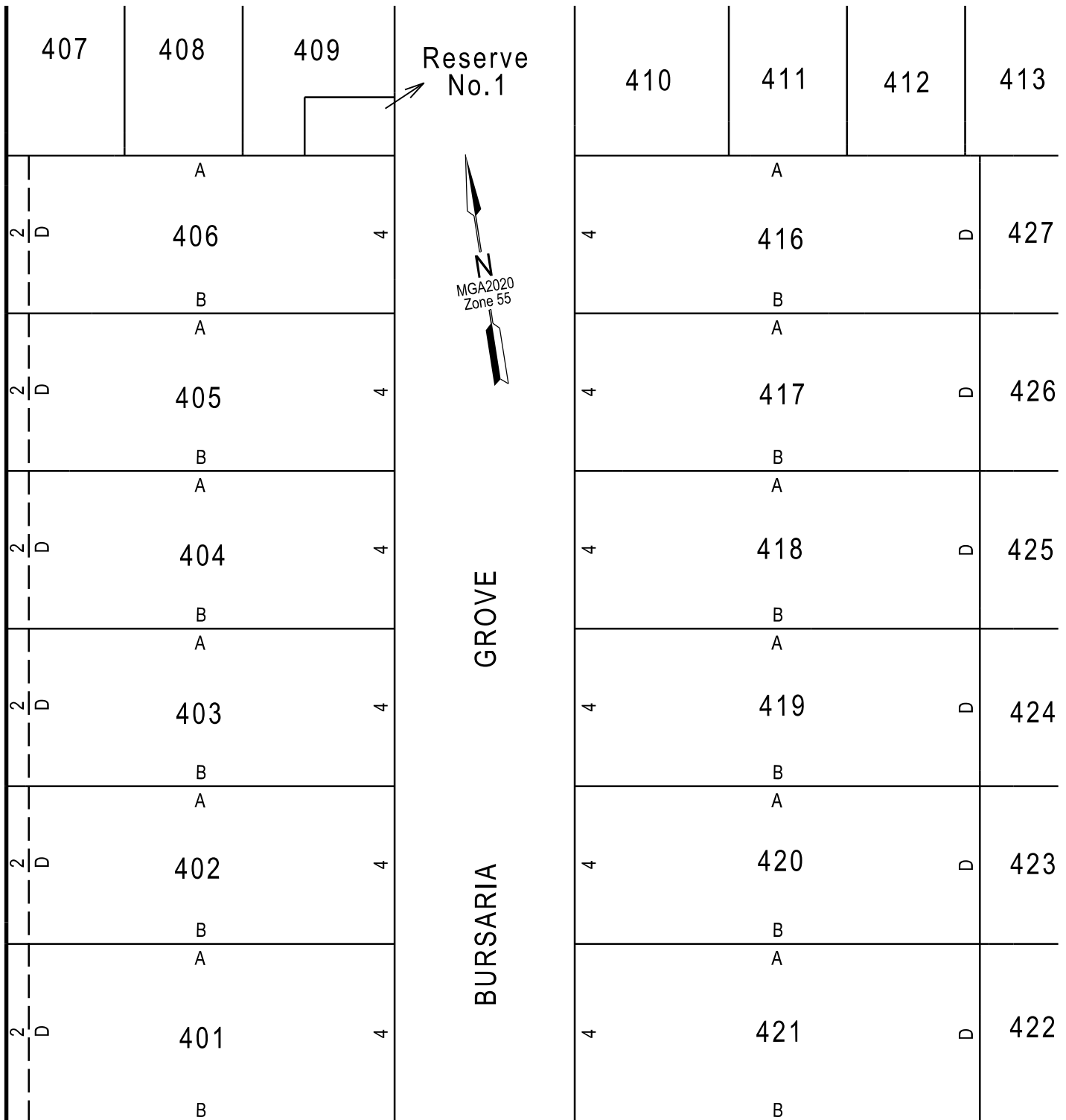

SEE SHEET 13

Memorandum of common provisions
Section 91A Transfer of Land Act 1958

406	2	D	B	407	4	DAMSELFLY WAY	460	
	2	D	A	B	408		4	459
		D	A	A	409		4	458
				C				457
416	3	D	C	410	4		456	
	3	D	A	B	411		4	455
	3	D	B	A	412		4	454
	3	D	B	A	413		4	453
427	3	D	A	B	414		4	452
			A	A	415		4	
			C					

Reserve
No. 1
BURSARIA GROVE

SEE SHEET 11

SEE SHEET 13



SEE SHEET 16

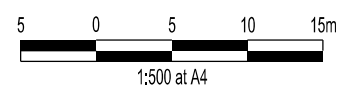

SEE SHEET 15

Memorandum of common provisions
Section 91A Transfer of Land Act 1958

SEE SHEET 12

SEE SHEET 14

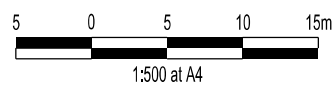
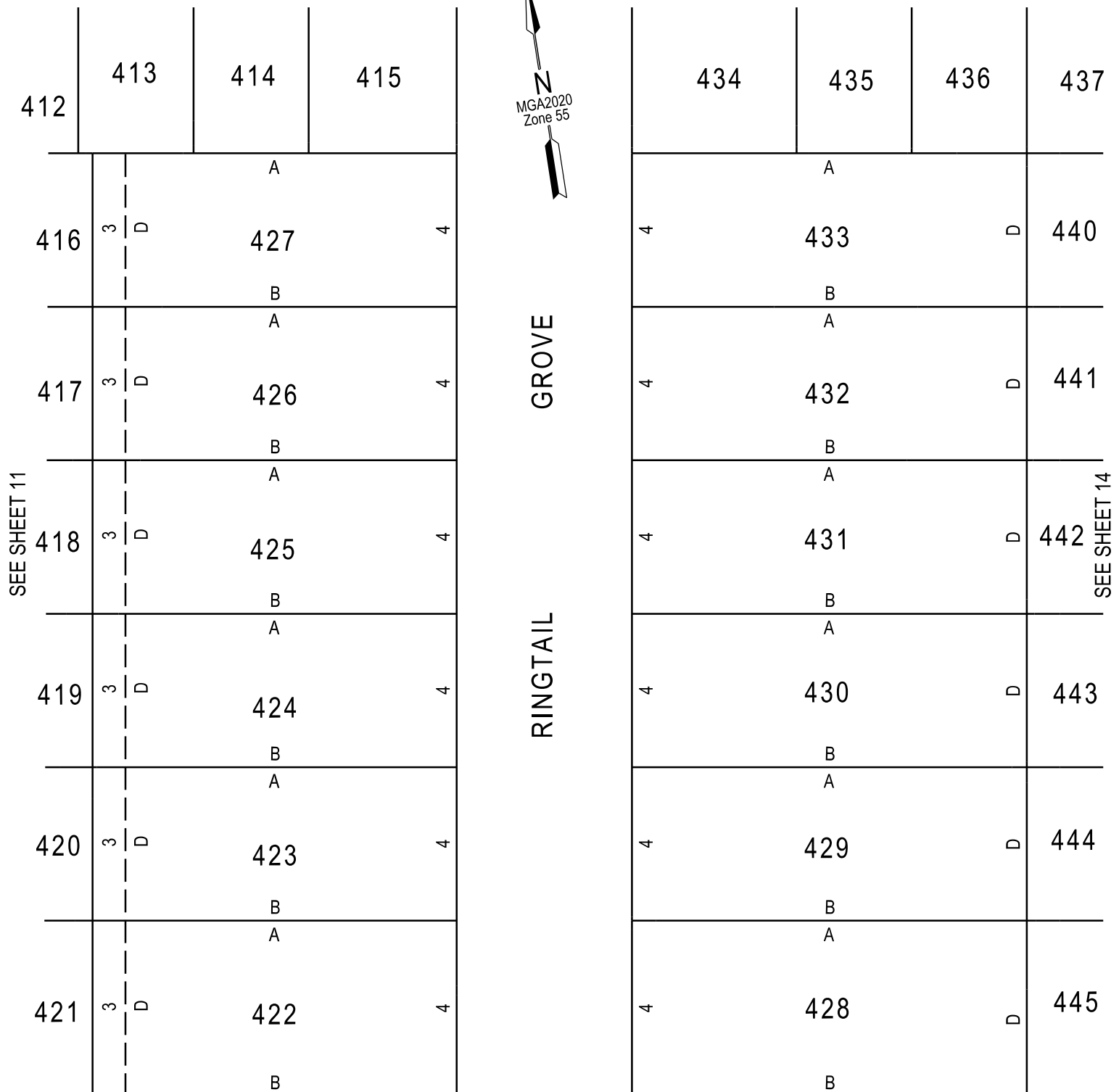

GROVE

RINGTAIL

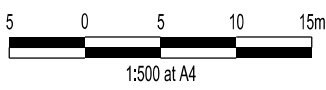
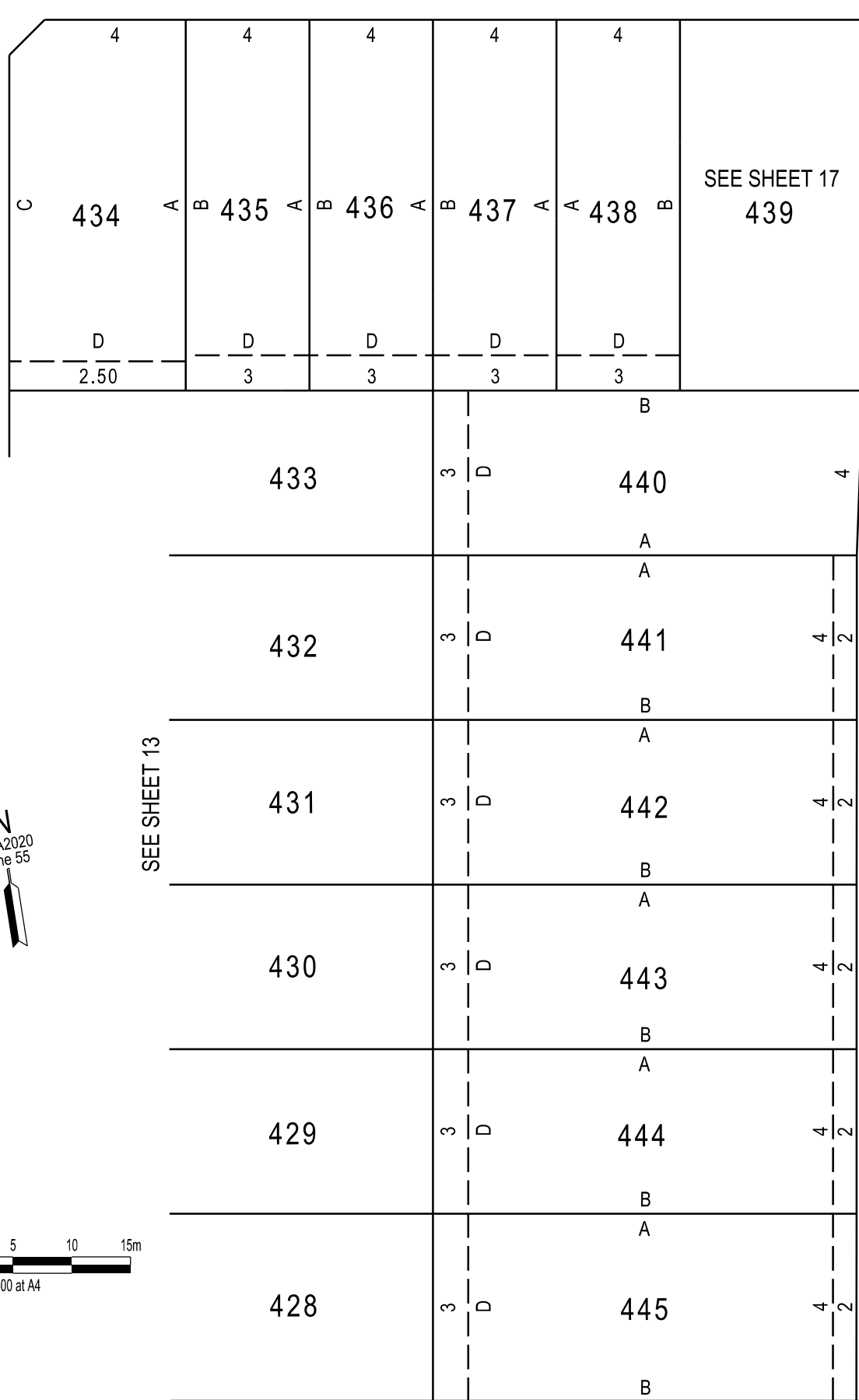

ROAD

MCMULLEN
ROAD

Memorandum of common provisions
Section 91A Transfer of Land Act 1958

SEE SHEET 16

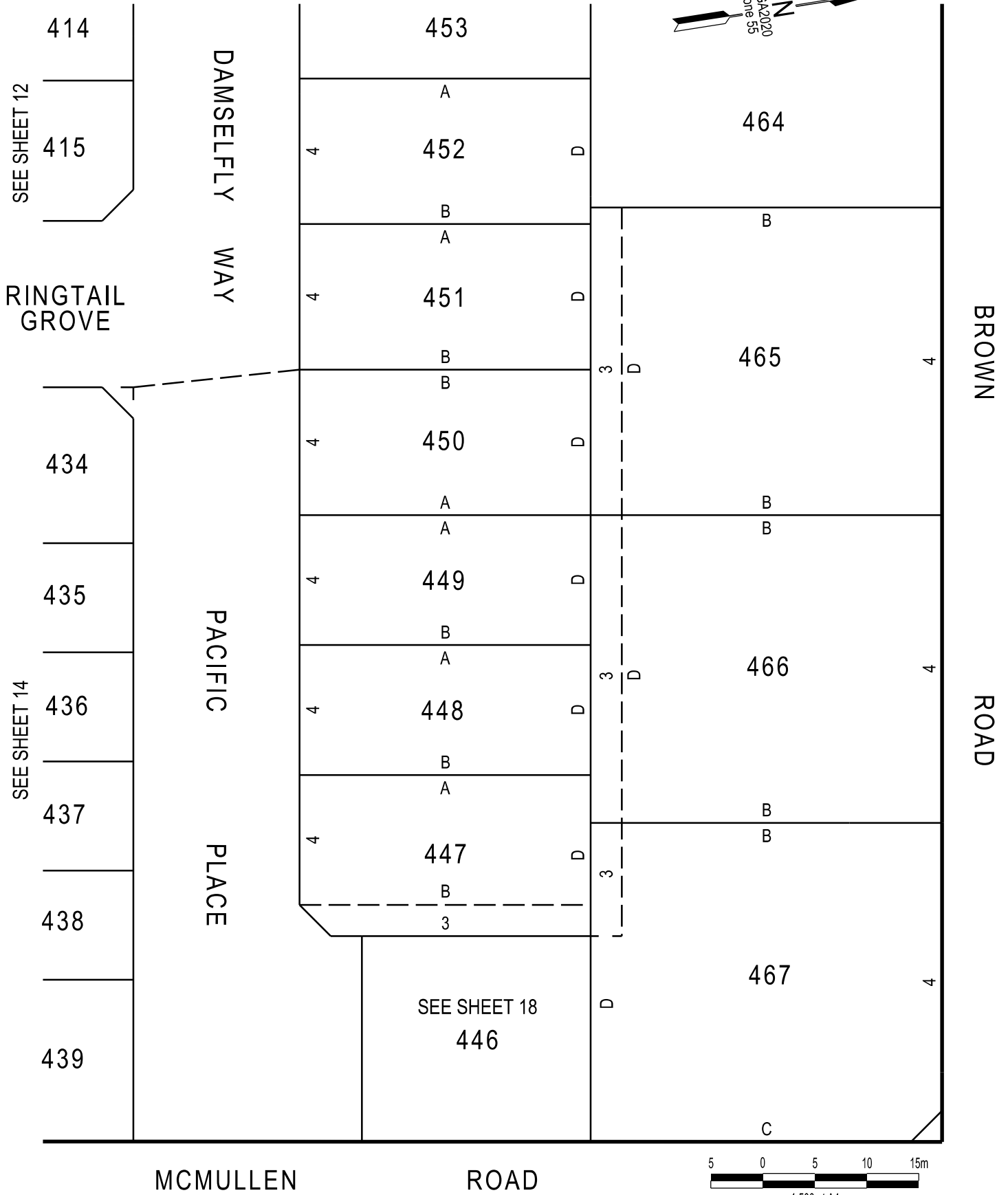
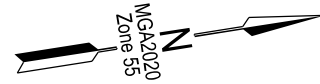

Memorandum of common provisions

Section 91A Transfer of Land Act 1958

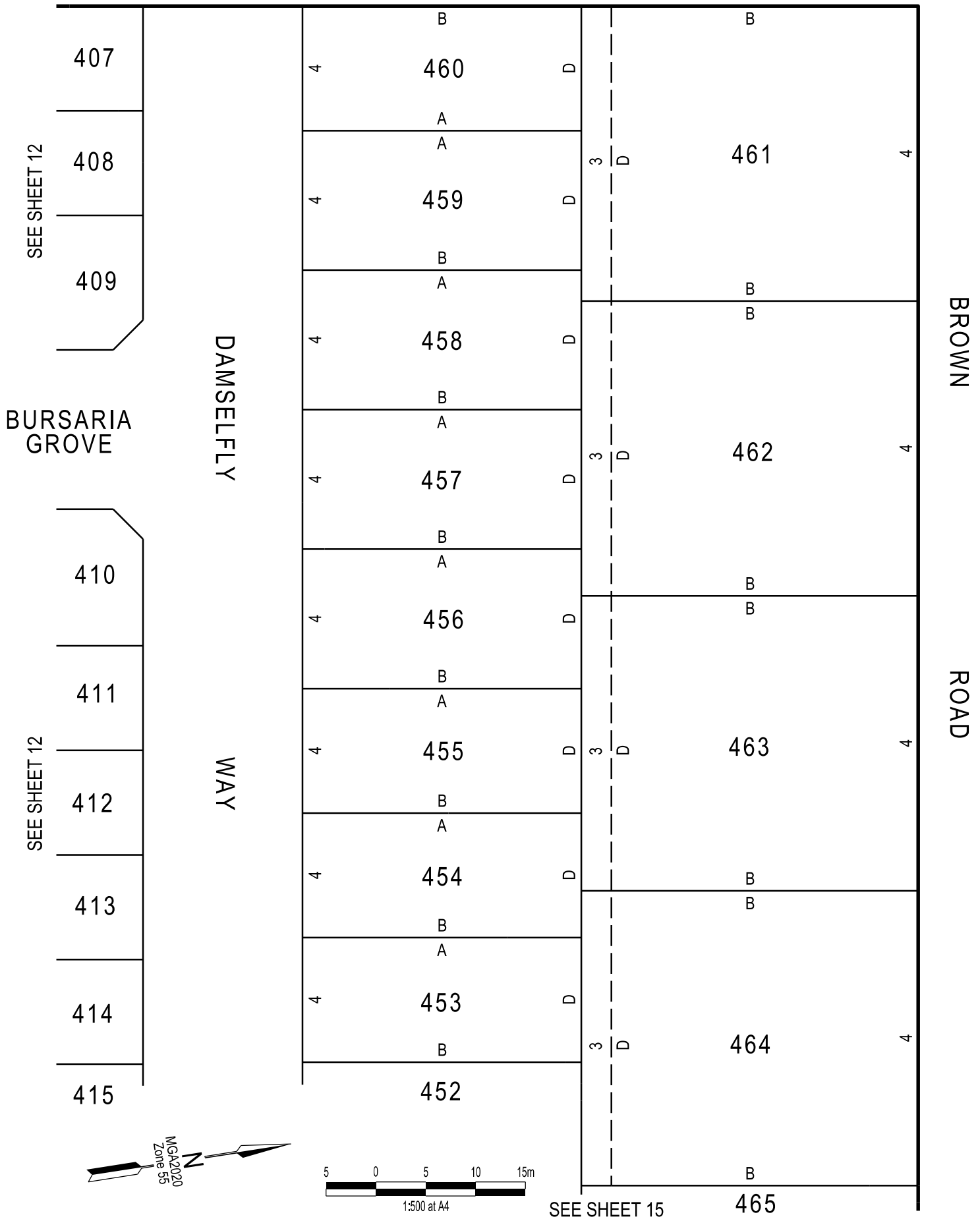

Memorandum of common provisions
Section 91A Transfer of Land Act 1958

SEE SHEET 15

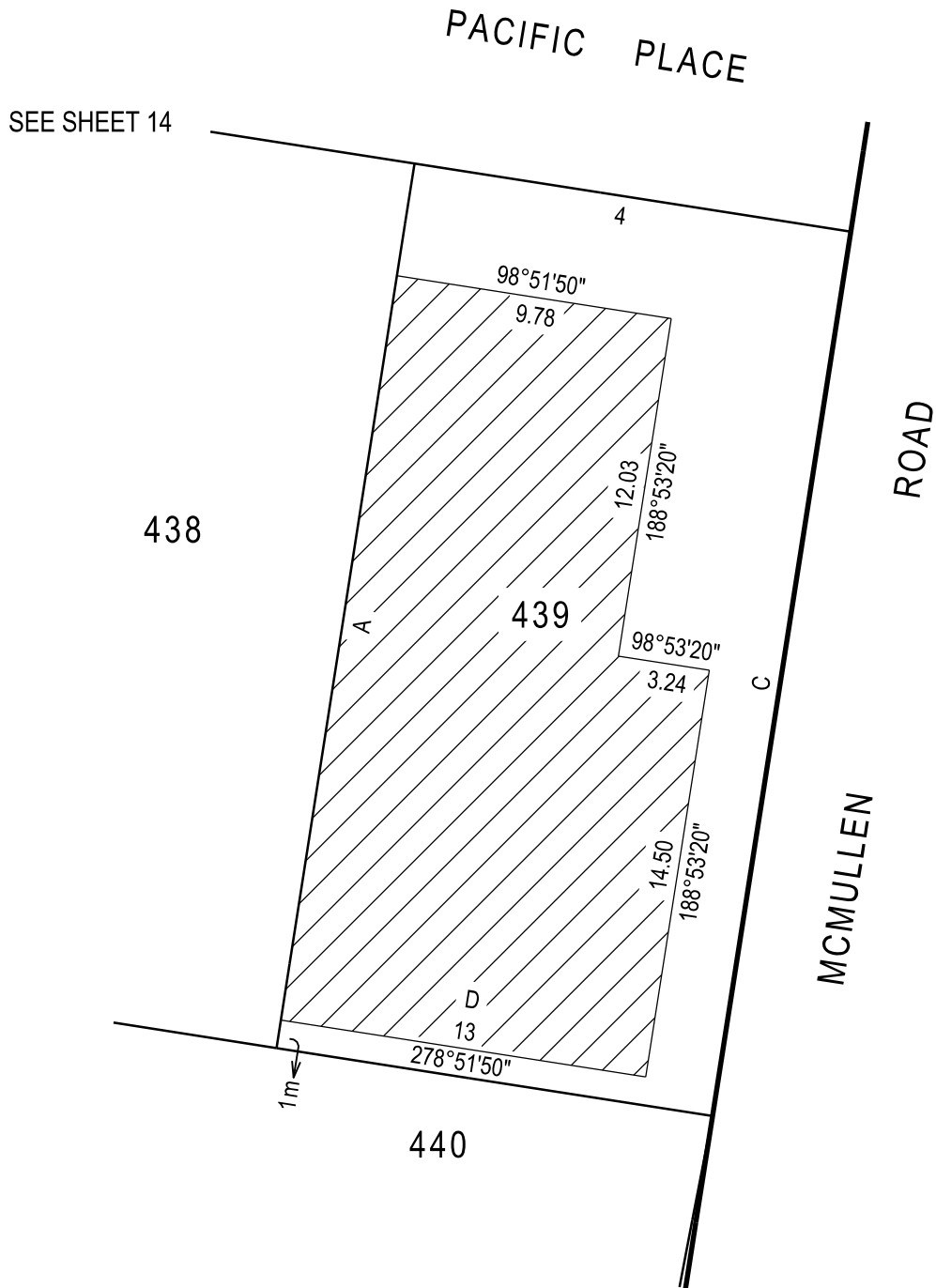

SEE SHEET 14

Memorandum of common provisions
Section 91A Transfer of Land Act 1958

SEE SHEET 15

